



PERFORMANCE RANGE

- Flow rate up to **6000 l/min** (360 m³/h)
- Head up to **95 m**

APPLICATION LIMITS

- Manometric suction lift up to **7 m**
- Liquid temperature between **-10 °C** and **+90 °C**
- Ambient temperature between **-10 °C** and **+40 °C**
- Max. pressure in pump body **10 bar** (PN10)
- Continuous service **S1**

CONSTRUCTION AND SAFETY STANDARDS

EN 60034-1
IEC 60034-1
CEI 2-3



Pump body dimensions in compliance with **EN 733**
REGULATION (EU) N. 547/2012

CERTIFICATIONS



INSTALLATION AND USE

- Water supply
- Pressure boosting
- Irrigation
- Water circulation in climatisation sets
- Cleaning sets
- Firefighting sets
- Industrial applications
- Agricultural applications

The pumps must be installed in enclosed places, or at least protected against inclement weather.

OPTIONALS AVAILABLE ON REQUEST

- Special mechanical seal
- Other voltages or 60 Hz frequency
- Compatibility with hotter or colder liquids
- Compatibility with hotter or colder ambients

GUARANTEE

2 years subject to terms and conditions

PERFORMANCE RANGE

50 Hz n= 2900 1/min HS= 0 m

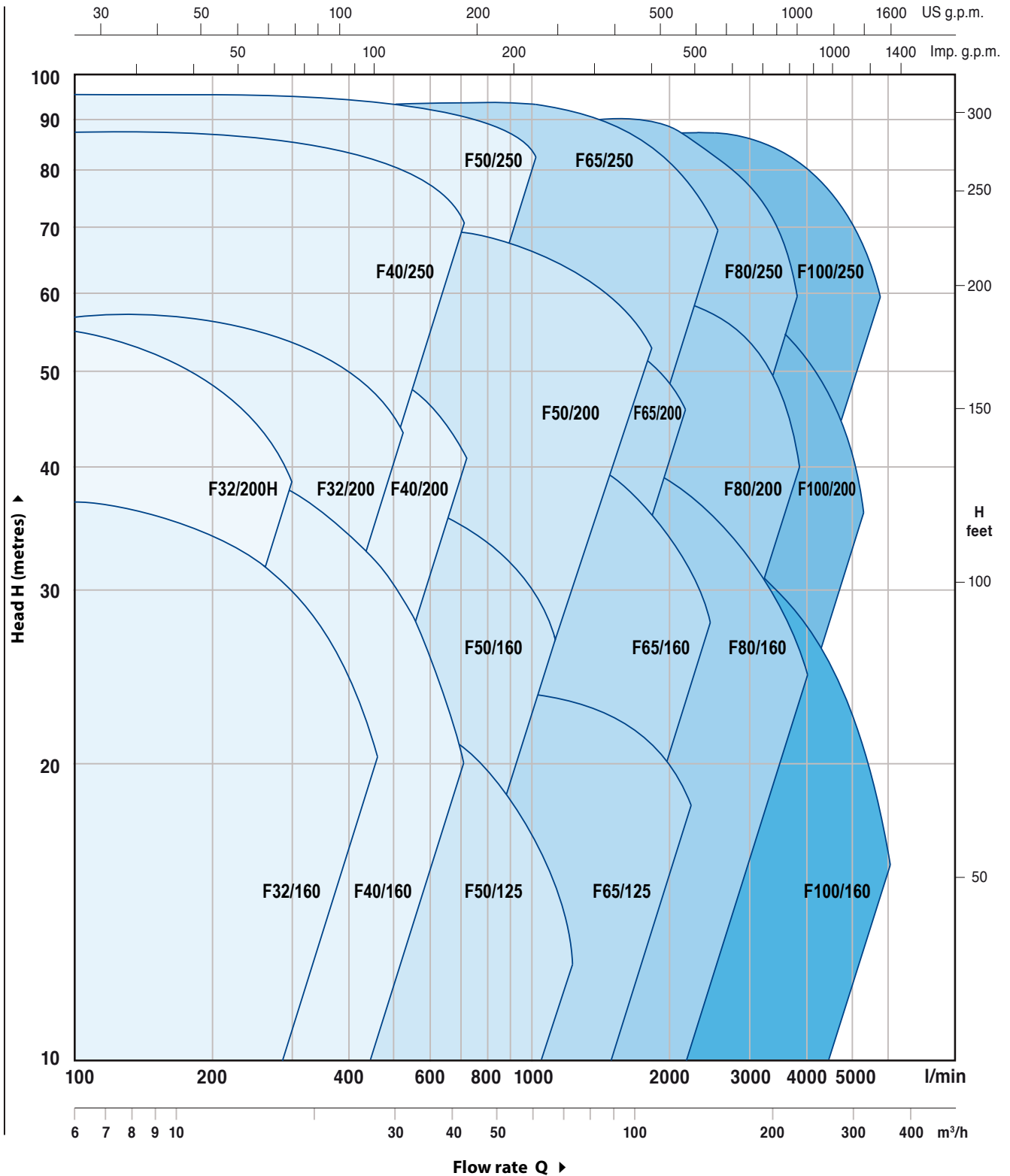

CHARACTERISTIC CURVES AND PERFORMANCE DATA

50 Hz n= 2900 1/min HS= 0 m

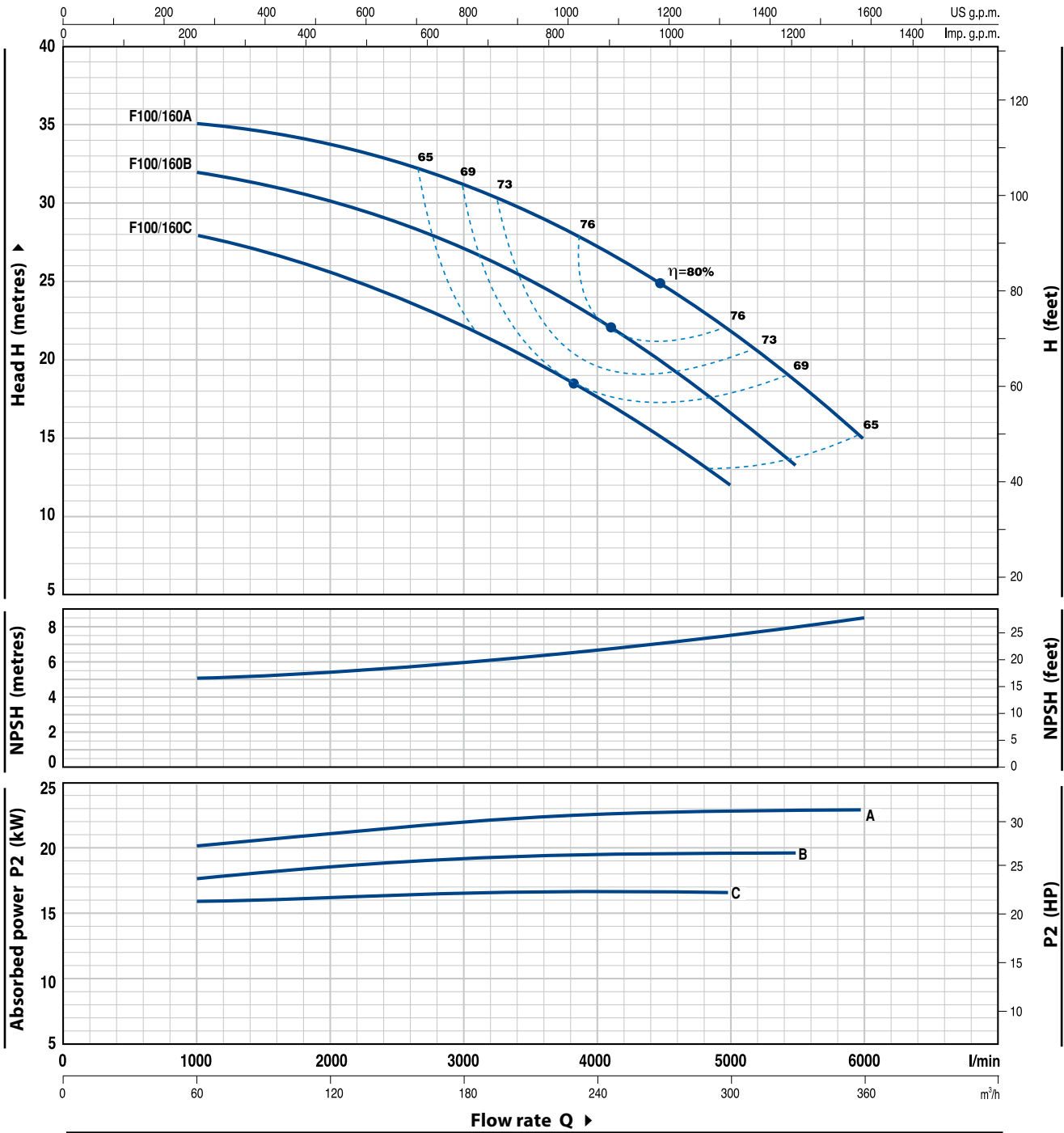

MODEL	POWER		Q	0	60	120	180	240	270	300	330	360
	kW	HP		0	1000	2000	3000	4000	4500	5000	5500	6000
Three-phase			H metres	0	1000	2000	3000	4000	4500	5000	5500	6000
F 100/160C	15	20		28	28	25.5	22	17.5	15	12		
F 100/160B	18.5	25		32	32	30	27	22.5	19.5	17	13	
F 100/160A	22	30		35	35	34	31	27	24.5	22	18	15

Q = Flow rate H = Total manometric head HS = Suction height

Tolerance of characteristic curves in compliance with EN ISO 9906 Grade 3.

POS.	COMPONENT	CONSTRUCTION CHARACTERISTICS					
1	PUMP BODY	Cast iron, complete with flanged suction and delivery ports					
2	COUNTERFLANGES	Steel, complete with ISO 228/1 thread					
3a	BODY BACKPLATE	Cast iron					
3b	MOTOR BRACKET	Cast iron					
4	IMPELLER	Brass for F32/160, F32/200, F40/160, F40/200, F50/125, F50/160 Cast iron for F40/250, F50/200, F50/250, F65/125, F65/160, F65/200, F65/250, F80/160, F80/200, F80/250, F100/160, F100/200, F100/250					
5	MOTOR SHAFT	Stainless steel EN 10088-3 - 1.4104					
6	MECHANICAL SEAL	Pump Model		Seal Model	Shaft Diameter	Materials Stationary ring Rotational ring Elastomer	
		F32/160 F50/125	F40/160	FN-20	Ø 20 mm	Graphite	Ceramic NBR
		F32/200 F50/160	F40/200 F65/125	FN-24	Ø 24 mm	Graphite	Ceramic NBR
		F50/200 F65/200 F100/160	F65/160 F80/160	FN-32 NU	Ø 32 mm	Graphite	Ceramic NBR
		F40/250 F65/250	F50/250 F80/200	FN-38	Ø 38 mm	Graphite	Ceramic NBR
		F80/250B F80/250A	F100/200 F100/250	FN-40 FH-45 NU	Ø 40 mm Ø 45 mm	Graphite	Ceramic NBR
						Graphite	Ceramic NBR
						Graphite	Ceramic NBR
7	BEARINGS	Pump Model		Pump Model			
		F32/160C F32/160B F40/160C F50/125C	6206 ZZ - C3 / 6204 ZZ	F32/200 F40/200 F50/160 F65/125	6307 ZZ - C3 / 6206 ZZ - C3		
		Fm32/160B F32/160A Fm40/160C F40/160B Fm50/125C F50/125B	6206 ZZ - C3 / 6205 ZZ	F40/250 F50/200 F50/250 F65/160 F65/200 F80/160 F100/160	6310 ZZ - C3 / 6308 ZZ - C3		
		F40/160A F50/125A	6306 ZZ - C3 / 6206 ZZ - C3	F65/250 F80/200 F80/250B F100/200	6312 ZZ - C3 / 6212 ZZ - C3		
			F80/250A F100/250	6314 ZZ - C3 / 6314 ZZ - C3			
8	CAPACITOR	Pump Single-phase		Capacitance (230 V or 240 V)			
		Fm32/160B		70 µF 450 VL			
		Fm40/160C		70 µF 450 VL			
		Fm50/125C		70 µF 450 VL			
9	ELECTRIC MOTOR	Fm: single-phase 230 V - 50 Hz with thermal overload protector built-in to the winding (up to 1.5 kW) F: three-phase 230/400 V - 50 Hz up to 4 kW 400/690 V - 50 Hz from 5.5 to 75 kW ☛ Pumps fitted with the three-phase motor option offer IE2 (IEC 60034-30) class high performance – Insulation: F class – Protection: IPX5					

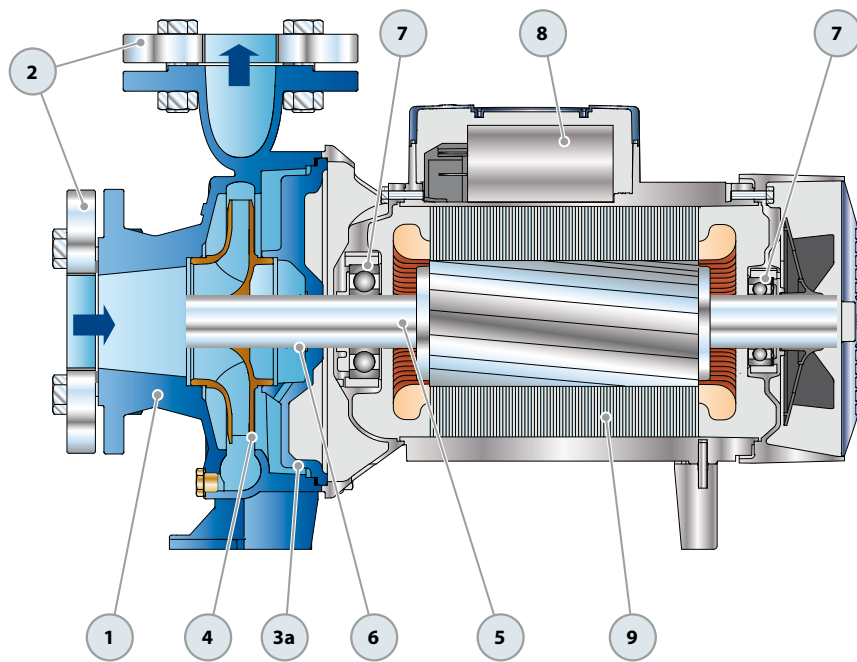

Single-phase version

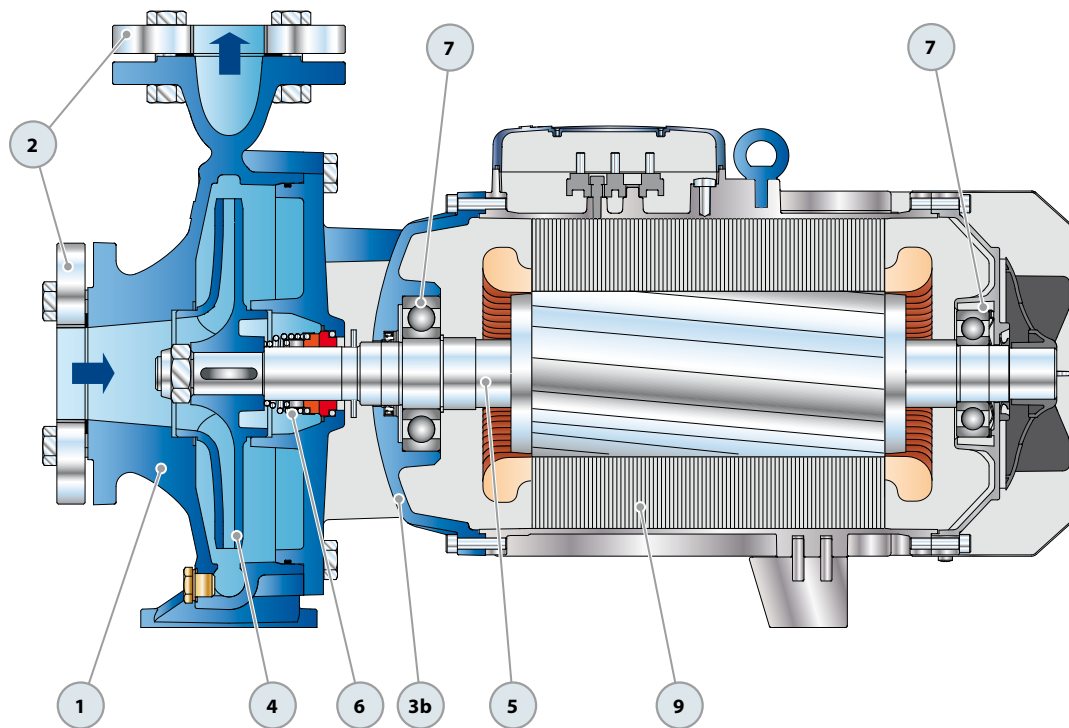

Three-phase version

DIMENSIONS AND WEIGHT

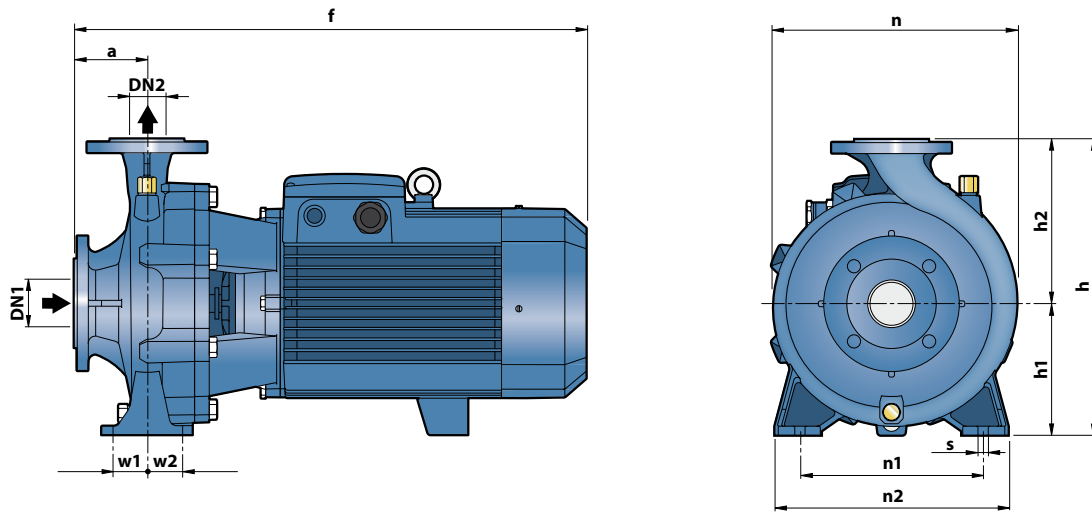

MODEL		PORTS		DIMENSIONS mm											kg *																									
Single-phase	Three-phase	DN1	DN2	a	f	h	h1	h2	n	n1	n2	w1	w2	s	1~	3~																								
-	F 32/160C	50	32	80	412	292	132	160	242	190	240	35	35	14	-	37.0																								
Fm 32/160B	F 32/160B				42.6										38.5																									
-	F 32/160A				431	340	160	180	270						270	190	240	35	35	14	-	42.6																		
-	F 32/200C				469																52.0																			
-	F 32/200B				515	340	160	180	270						270	190	240	35	35	14	-	57.0																		
-	F 32/200A				469																61.0																			
-	F 32/200BH				412	65	40	535	340						160	180	275	212	265	47.5	47.5	14	-	47.9																
-	F 32/200AH				431																		51.1																	
Fm 40/160C	F 40/160C				465																		43.9	40.0																
-	F 40/160B				515																		340	160	180	275	212	265	35	35	14	-	44.0							
-	F 40/160A	465	50.1																																					
-	F 40/200B	606	65	40	606					405	180	225	328	250									320	47.5	47.5	14	-	61.0												
-	F 40/200A	701																									67.0													
-	F 40/250C	431																									340	160	180	269	212	265	35	35	14	-	103.0			
-	F 40/250B	450																																		109.0				
-	F 40/250A	484																									65	50	711	360	200	316	212	265	47.5	47.5	14	-	125.0	
Fm 50/125C	F 50/125C	489				44.2	40.1																																	
-	F 50/125B	535				340	160	180	269						212	265	35	35	14	-	44.1																			
-	F 50/125A	489																		50.7																				
-	F 50/160C	616				65	50	711	360						200	316	212	265	47.5	47.5	14	-																55.0		
-	F 50/160B	711																				60.6																		
-	F 50/160A	535	340	160	180					269	212	265	35	35								14	-	64.7																
-	F 50/200C	616																					106.0																	
-	F 50/200B	711	65	50	711					360	200	316	212	265								47.5	47.5	14	-	128.0														
-	F 50/200A	711																							135.0															
-	F 50/200AR	743																							340	160	180	291	212	280	47.5	47.5	14	-	147.0					
-	F 50/250D	743																																147.0						
-	F 50/250C	606																							65	50	606	405	180	225	337	250	320	60	60	18	-	106.0		
-	F 50/250B	701																																			113.4			
-	F 50/250A	701				340	160	180	225						337	250	320	60	60	18	-																129.6			
-	F 50/250AR	733																			146.0																			
-	F 65/125C	511				80	65	511	340						160	180	291	212	280	47.5	47.5																14	-	155.0	
-	F 65/125B	557																																				62.7		
-	F 65/125A	557	340	160	180					291	212	280	47.5	47.5								14	-	66.8																
-	F 65/160C	621																					74.0																	
-	F 65/160B	621	80	65	621					360	200	300	300	212								280	47.5	47.5														14	-	100.0
-	F 65/160A	716																																					106.5	
-	F 65/200B	719																							340	160	180	225	337	250	320	60	60	18	-	123.0				
-	F 65/200A	719																																	128.0					
-	F 65/200AR	751																							80	80	751	405	180	225	340	250	320	60	60	18			-	125.0
-	F 80/160D	652																																					153.1	
-	F 80/160C	652				340	160	180	225						337	250	320	60	60	18	-																153.1			
-	F 80/160B	747																			111.5																			
-	F 80/160A	779				100	80	779	405						180	225	330	250	320	60	60																18		-	126.0
-	F 100/160C	758																																					143.5	
-	F 100/160B	758	340	160	180					225	337	250	320	60								60	18	-														139.0		
-	F 100/160A	790																						153.7																
-	F 100/160A	790	125	100	790					480	200	280	362	280								360	60	60														18	-	165.0

(*weight includes counterflanges)

DIMENSIONS AND WEIGHT

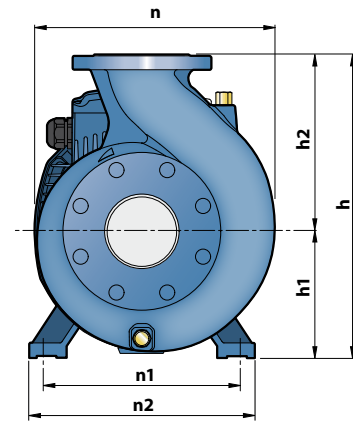
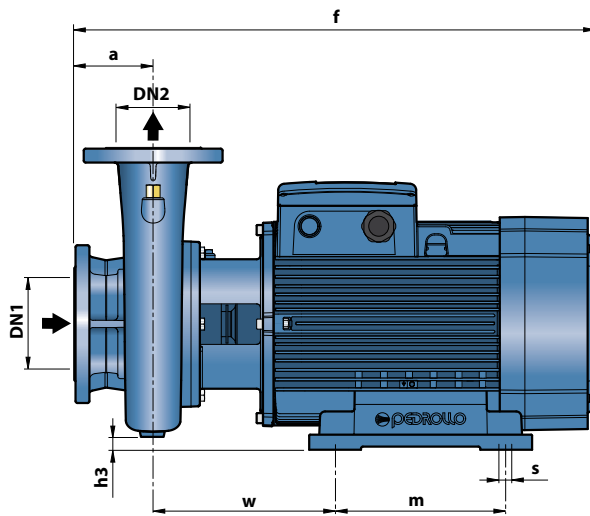

DN FLANGES	D mm	K mm	HOLES	
			N°	Ø (mm)
32	140	100	4	18
40	150	110		
50	165	125		
65	185	145		
80	200	160	8	18
100	220	180		
125	250	210		

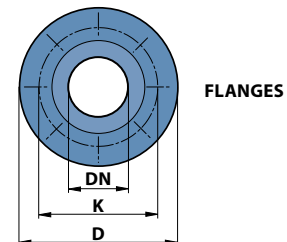

MODEL	PORTS		DIMENSIONS mm											kg *	
	DN1	DN2	a	f	h	h1	h2	h3	n	n1	n2	w	m		s
Three-phase															3~
F 65/250C	80	65	100	796	450	200	250	15	369	318	360	269.5	305	18.5	210.0
F 65/250B				847											230.0
F 65/250A				847											230.0
F 80/200B				824											212.0
F 80/200A	100	80	125	875	430	280	25	360	318	360	269.5	305	18.5	222.5	
F 80/250B				872										245.0	
F 80/250A				1015										497.0	
F 100/200C	125	100	140	824	480	200	280	0	391	318	360	269.5	305	18.5	208.5
F 100/200B				875											239.0
F 100/200A				875											240.0
F 100/250B				1036											498.5
F 100/250A					620	250	280	45	490	400	490	300	350	24	498.5

(*weight includes counterflanges)

COUNTERFLANGES

DN FLANGES	F COUNTERFLANGES	D mm	K mm	HOLES	
				N°	Ø (mm)
32	1¼"	140	100	4	18
40	1½"	150	110		
50	2"	165	125		
65	2½"	185	145		
80	3"	200	160	8	18
100	4"	220	180		
125	5"	250	210		

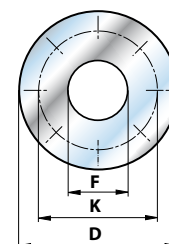

ABSORPTION

MODEL	VOLTAGE (single-phase)	
	230 V	240 V
Single-phase		
Fm 32/160B	15.0 A	13.8 A
Fm 40/160C	15.0 A	13.8 A
Fm 50/125C	15.0 A	13.8 A

MODEL	VOLTAGE (three-phase)		
	230÷240 V	400÷415 V	690÷720 V
Three-phase			
F 32/160C	7.5 A	4.3 A	2.5 A
F 32/160B	10.0 A	5.8 A	3.4 A
F 32/160A	12.0 A	7.3 A	4.2 A
F 32/200C	17.9 A	10.3 A	5.9 A
F 32/200B	-	11.7 A	6.7 A
F 32/200A	-	14.9 A	8.6 A
F 32/200BH	12.6 A	7.3 A	4.2 A
F 32/200AH	15.4 A	8.9 A	5.1 A
F 40/160C	9.9 A	5.7 A	3.3 A
F 40/160B	12.0 A	6.9 A	4.0 A
F 40/160A	17.2 A	9.9 A	5.7 A
F 40/200B	-	12.6 A	7.3 A
F 40/200A	-	15.6 A	9.0 A
F 40/250C	-	21.0 A	12.1 A
F 40/250B	-	23.5 A	13.6 A
F 40/250A	-	30.5 A	17.6 A
F 50/125C	9.4 A	5.4 A	3.1 A
F 50/125B	12.0 A	6.9 A	4.0 A
F 50/125A	16.3 A	9.4 A	5.4 A
F 50/160C	15.8 A	9.1 A	5.3 A
F 50/160B	-	12.3 A	7.1 A
F 50/160A	-	15.5 A	8.9 A
F 50/200C	-	23 A	13.3 A
F 50/200B	-	29.5 A	17 A
F 50/200A	-	34.5 A	20 A
F 50/200AR	-	41.5 A	24 A
F 50/250D	-	17.2 A	9.9 A
F 50/250C	-	21.0 A	12.0 A
F 50/250B	-	27.0 A	15.6 A
F 50/250A	-	34.0 A	19.6 A
F 50/250AR	-	41.0 A	24.0 A
F 65/125C	17.5 A	10.0 A	5.8 A
F 65/125B	-	12.0 A	7.0 A
F 65/125A	-	16.5 A	9.5 A
F 65/160C	-	19.0 A	11.0 A
F 65/160B	-	23.0 A	13.5 A
F 65/160A	-	27.5 A	16.0 A
F 65/200B	-	30.0 A	17.3 A
F 65/200A	-	35.0 A	20.2 A
F 65/200AR	-	41.0 A	24.0 A
F 65/250C	-	53.0 A	31.0 A
F 65/250B	-	65.0 A	38.0 A
F 65/250A	-	79.0 A	46.0 A
F 80/160D	-	22.0 A	13.0 A
F 80/160C	-	29.0 A	17.0 A
F 80/160B	-	34.5 A	20.0 A
F 80/160A	-	39.0 A	22.5 A
F 80/200B	-	53.0 A	31.0 A
F 80/200A	-	65.0 A	38.0 A
F 80/250B	-	79.0 A	46.0 A
F 80/250A	-	98.0 A	57.0 A
F 100/160C	-	31.0 A	18.0 A
F 100/160B	-	36.0 A	21.0 A
F 100/160A	-	42.0 A	24.0 A
F 100/200C	-	53.0 A	31.0 A
F 100/200B	-	65.0 A	38.0 A
F 100/200A	-	79.0 A	46.0 A
F 100/250B	-	98.0 A	57.0 A
F 100/250A	-	126.0A	73.0 A

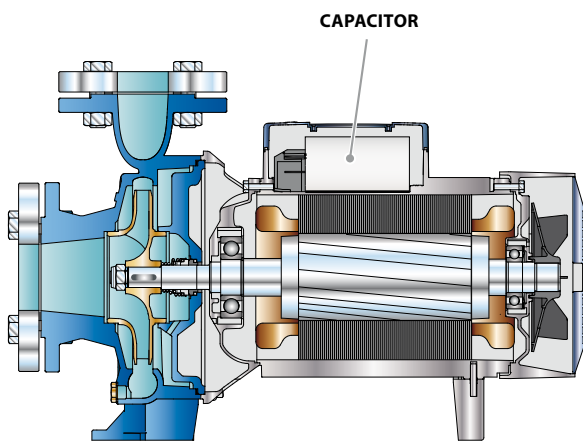

Single-phase version

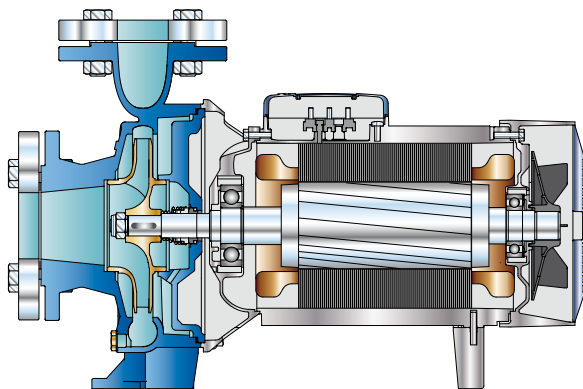

Three-phase version

REGULATION (EU) N. 547/2012

- Minimum efficiency index $MEI \geq 0,10$ for water pumps according to the (EU) Regulation current from the 1th of January 2013.
- The benchmark for most efficient water pumps is $MEI \geq 0,70$.
- The efficiency of a pump with a trimmed impeller is usually lower than that of a pump with the full impeller diameter. The trimming of the impeller will adapt the pump to a fixed duty point, leading to reduced energy consumption. The minimum efficiency index (MEI) is based on the full impeller diameter.
- The operation of this water pump with variable duty points may be more efficient and economic when controlled, for example, by the use of a variable speed drive that matches the pump duty to the system.
- Information on benchmark efficiency is available www.europump.org/efficiencycharts.