



### PERFORMANCE RANGE

- Flow rate up to **6000 l/min** (360 m<sup>3</sup>/h)
- Head up to **95 m**

### APPLICATION LIMITS

- Manometric suction lift up to **7 m**
- Liquid temperature between **-10 °C** and **+90 °C**
- Ambient temperature between **-10 °C** and **+40 °C**
- Max. pressure in pump body **10 bar** (PN10)
- Continuous service **S1**

### CONSTRUCTION AND SAFETY STANDARDS

EN 60034-1  
IEC 60034-1  
CEI 2-3



Pump body dimensions in compliance with **EN 733**  
**REGULATION (EU) N. 547/2012**

### CERTIFICATIONS



### INSTALLATION AND USE

- Water supply
- Pressure boosting
- Irrigation
- Water circulation in climatisation sets
- Cleaning sets
- Firefighting sets
- Industrial applications
- Agricultural applications

The pumps must be installed in enclosed places, or at least protected against inclement weather.

### OPTIONALS AVAILABLE ON REQUEST

- Special mechanical seal
- Other voltages or 60 Hz frequency
- Compatibility with hotter or colder liquids
- Compatibility with hotter or colder ambients

### GUARANTEE

2 years subject to terms and conditions

**PERFORMANCE RANGE**

**50 Hz n= 2900 1/min HS= 0 m**

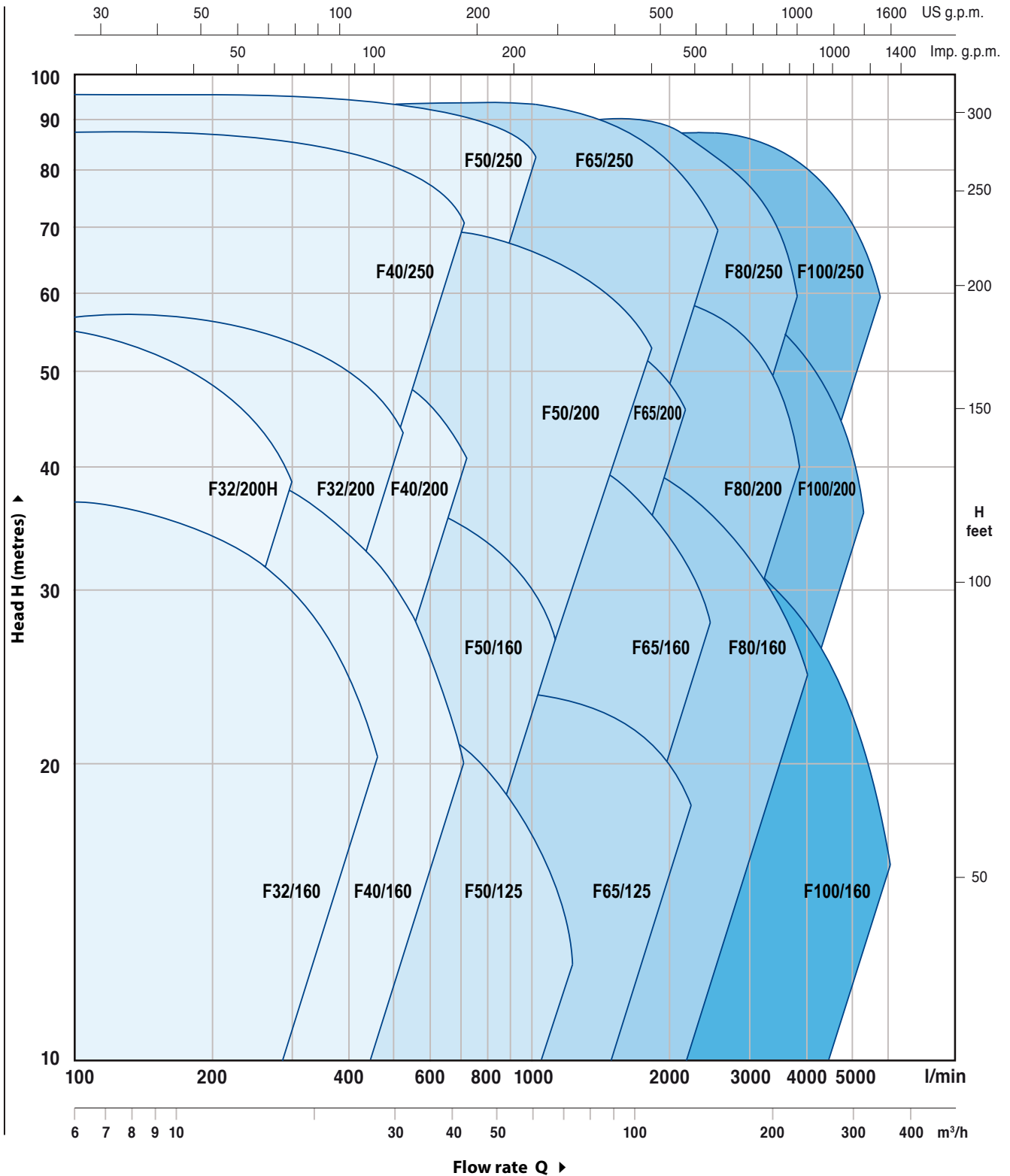

# F50/125

## CHARACTERISTIC CURVES AND PERFORMANCE DATA

50 Hz n= 2900 1/min HS= 0 m

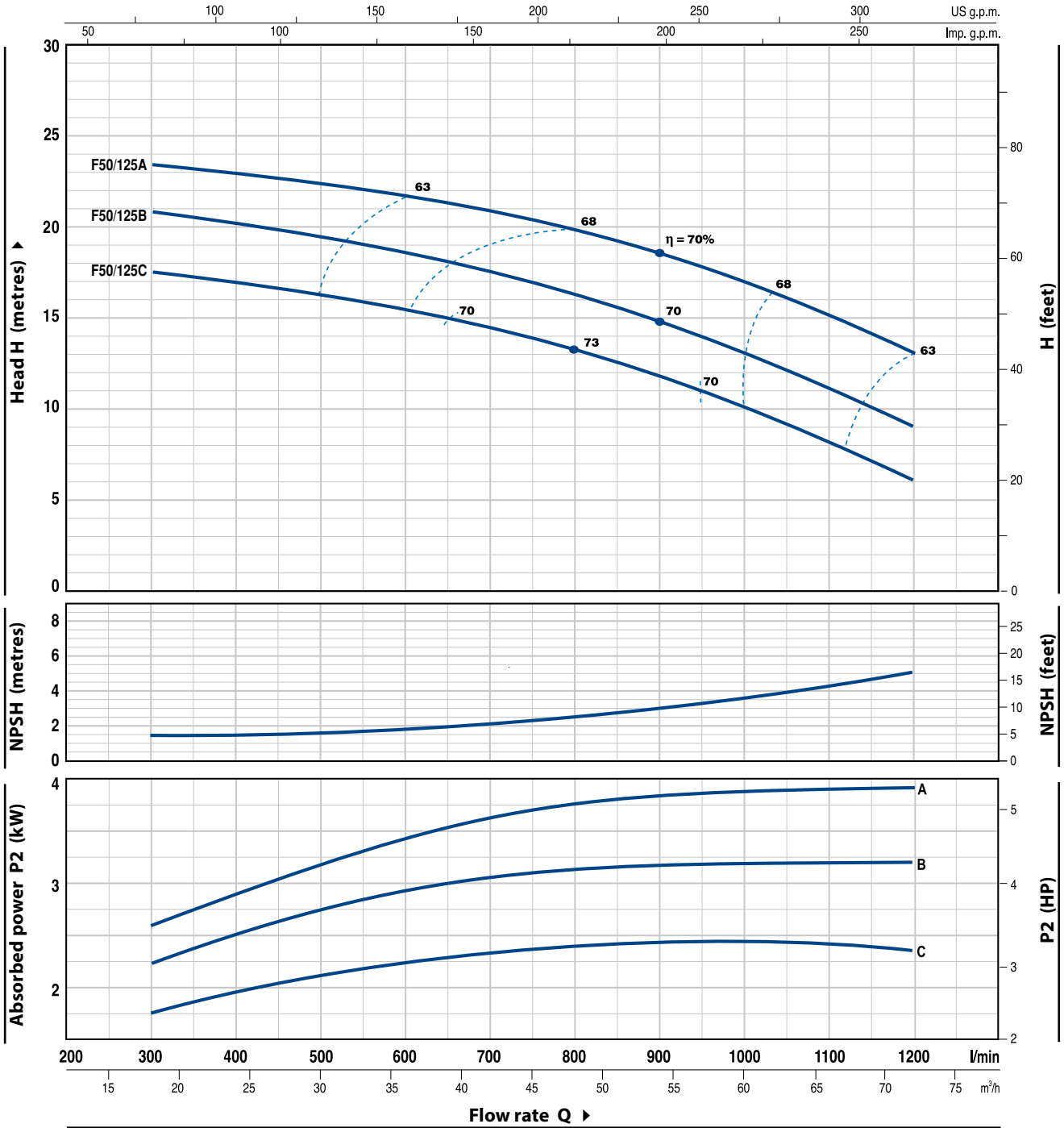

MODEL		POWER		Q	Flow rate													
Single-phase	Three-phase	kW	HP		0	18	24	30	36	42	48	54	60	66	72			
Fm 50/125C	F 50/125C	2.2	3	H metres	18.5	17.5	17	16.5	15.5	14.8	13.5	12	10.5	8.2	6			
-	F 50/125B	3	4		21.5	20.7	20	19.5	18.8	17.8	16.5	15	13.5	11.2	9			
-	F 50/125A	4	5.5		24.5	23.5	23	22.5	21.8	20.8	19.5	18.3	16.8	15	13			

Q = Flow rate H = Total manometric head HS = Suction height

Tolerance of characteristic curves in compliance with EN ISO 9906 Grade 3.

POS.	COMPONENT	CONSTRUCTION CHARACTERISTICS						
1	<b>PUMP BODY</b>	Cast iron, complete with flanged suction and delivery ports						
2	<b>COUNTERFLANGES</b>	Steel, complete with ISO 228/1 thread						
3a	<b>BODY BACKPLATE</b>	Cast iron						
3b	<b>MOTOR BRACKET</b>	Cast iron						
4	<b>IMPELLER</b>	Brass for F32/160, F32/200, F40/160, F40/200, F50/125, F50/160 Cast iron for F40/250, F50/200, F50/250, F65/125, F65/160, F65/200, F65/250, F80/160, F80/200, F80/250, F100/160, F100/200, F100/250						
5	<b>MOTOR SHAFT</b>	Stainless steel EN 10088-3 - 1.4104						
6	<b>MECHANICAL SEAL</b>	<b>Pump Model</b>		<b>Seal Model</b>	<b>Shaft Diameter</b>	<b>Materials</b> Stationary ring    Rotational ring    Elastomer		
		F32/160 F50/125	F40/160	<b>FN-20</b>	<b>Ø 20 mm</b>	Graphite	Ceramic    NBR	
		F32/200 F50/160	F40/200 F65/125	<b>FN-24</b>	<b>Ø 24 mm</b>	Graphite	Ceramic    NBR	
		F50/200 F65/200 F100/160	F65/160 F80/160	<b>FN-32 NU</b>	<b>Ø 32 mm</b>	Graphite	Ceramic    NBR	
		F40/250 F65/250 F80/250B F80/250A	F50/250 F80/200 F100/200 F100/250	<b>FN-38</b> <b>FN-40</b> <b>FH-45 NU</b>	<b>Ø 38 mm</b> <b>Ø 40 mm</b> <b>Ø 45 mm</b>	Graphite	Ceramic    NBR Ceramic    NBR Ceramic    NBR	
7	<b>BEARINGS</b>	<b>Pump Model</b>		<b>Pump Model</b>				
		F32/160C F32/160B F40/160C F50/125C	<b>6206 ZZ - C3 / 6204 ZZ</b>	F32/200 F40/200 F50/160 F65/125	<b>6307 ZZ - C3 / 6206 ZZ - C3</b>			
		Fm32/160B F32/160A Fm40/160C F40/160B Fm50/125C F50/125B	<b>6206 ZZ - C3 / 6205 ZZ</b>	F40/250 F50/200 F50/250 F65/160 F65/200 F80/160 F100/160	<b>6310 ZZ - C3 / 6308 ZZ - C3</b>			
		F40/160A F50/125A	<b>6306 ZZ - C3 / 6206 ZZ - C3</b>	F65/250 F80/200 F80/250B F100/200	<b>6312 ZZ - C3 / 6212 ZZ - C3</b>			
				F80/250A F100/250	<b>6314 ZZ - C3 / 6314 ZZ - C3</b>			
8	<b>CAPACITOR</b>	<b>Pump Single-phase</b>		<b>Capacitance (230 V or 240 V)</b>				
		Fm32/160B		<b>70 µF 450 VL</b>				
		Fm40/160C		<b>70 µF 450 VL</b>				
		Fm50/125C		<b>70 µF 450 VL</b>				
9	<b>ELECTRIC MOTOR</b>	<b>Fm:</b> single-phase 230 V - 50 Hz with thermal overload protector built-in to the winding (up to 1.5 kW) <b>F:</b> <b>three-phase 230/400 V - 50 Hz up to 4 kW</b> <b>400/690 V - 50 Hz from 5.5 to 75 kW</b> <b>☛ Pumps fitted with the three-phase motor option offer IE2 (IEC 60034-30) class high performance</b> – Insulation: F class – Protection: IPX5						

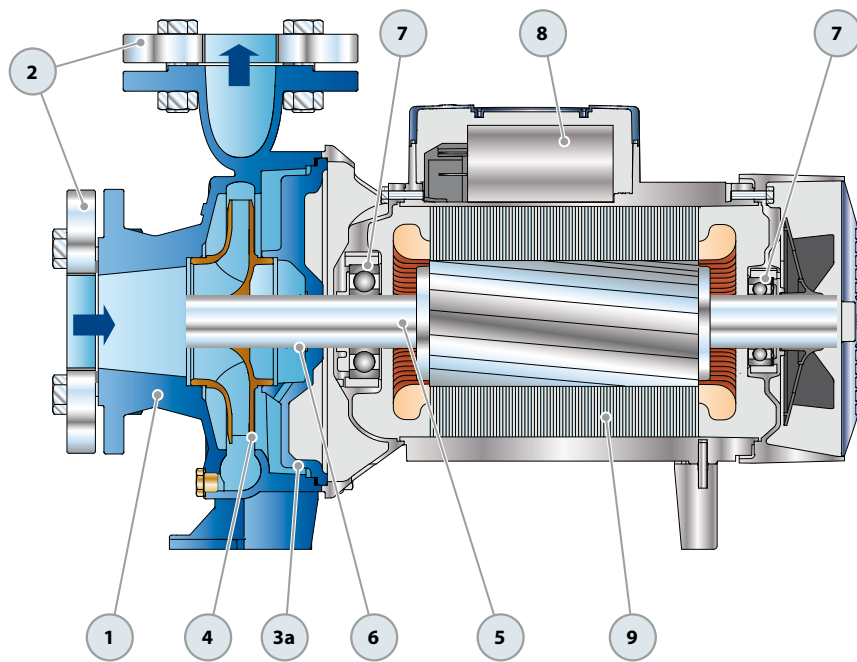

**Single-phase version**

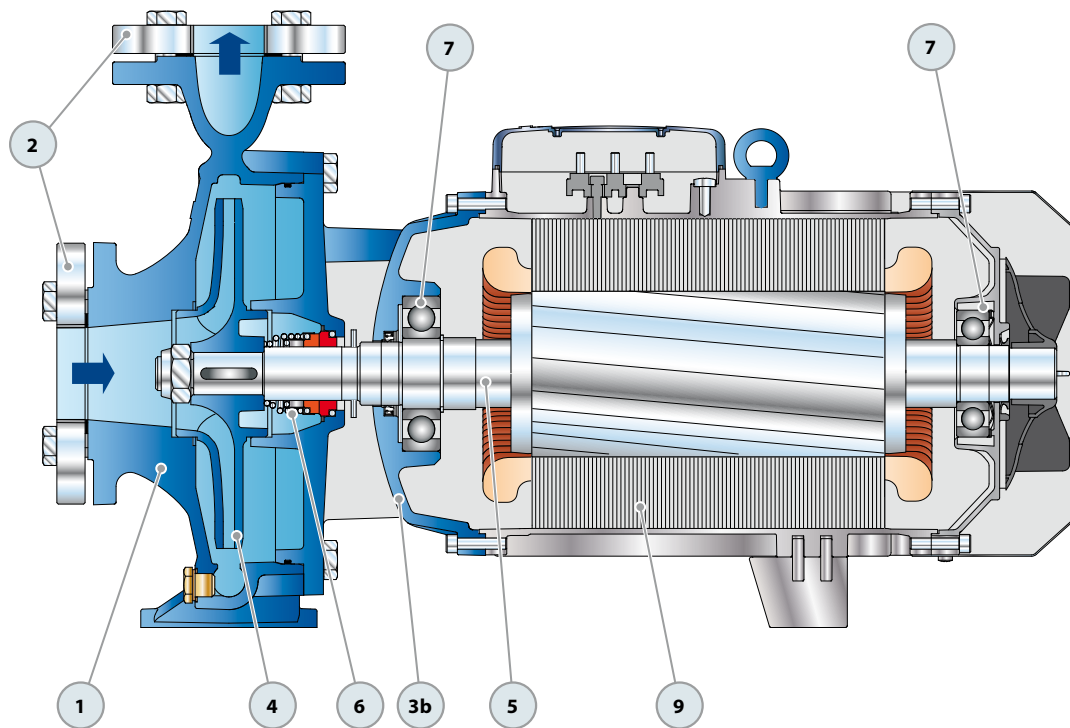

**Three-phase version**

## DIMENSIONS AND WEIGHT

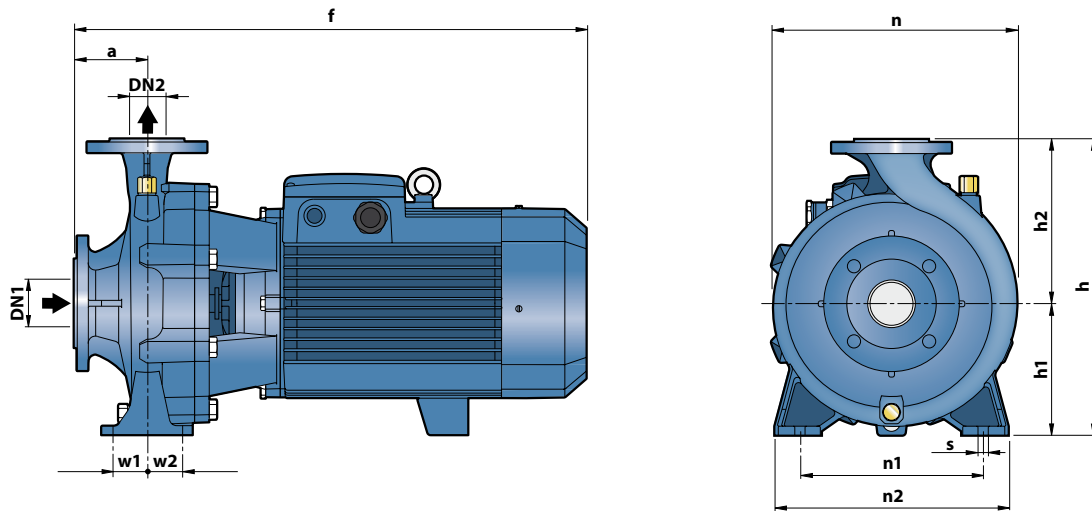

MODEL		PORTS		DIMENSIONS mm											kg *	
Single-phase	Three-phase	DN1	DN2	a	f	h	h1	h2	n	n1	n2	w1	w2	s	1~	3~
-	F 32/160C	50	32	80	412	292	132	160	242	190	240	35	35	14	-	37.0
Fm 32/160B	F 32/160B				42.6										38.5	
-	F 32/160A				-										42.6	
-	F 32/200C				-										52.0	
-	F 32/200B				-										57.0	
-	F 32/200A				-										61.0	
-	F 32/200BH				-										47.9	
-	F 32/200AH				-										51.1	
Fm 40/160C	F 40/160C				-										43.9	40.0
-	F 40/160B				-										-	44.0
-	F 40/160A	-	-	50.1												
-	F 40/200B	65	40	535	340	160	180	275	212	265	47.5	47.5	14	-	61.0	
-	F 40/200A				-									67.0		
-	F 40/250C				-									103.0		
-	F 40/250B				-									109.0		
-	F 40/250A				-									125.0		
Fm 50/125C	F 50/125C				-									44.2	40.1	
-	F 50/125B				-									-	44.1	
-	F 50/125A				-									-	50.7	
-	F 50/160C				-									-	55.0	
-	F 50/160B				-									-	60.6	
-	F 50/160A	-	-	64.7												
-	F 50/200C	65	50	616	160	160	180	269	212	265	35	35	14	-	106.0	
-	F 50/200B				-									128.0		
-	F 50/200A				-									135.0		
-	F 50/200AR				-									147.0		
-	F 50/250D				-									106.0		
-	F 50/250C				-									113.4		
-	F 50/250B				-									129.6		
-	F 50/250A				-									146.0		
-	F 50/250AR				-									155.0		
-	F 65/125C				80									65	511	340
-	F 65/125B	-	66.8													
-	F 65/125A	-	74.0													
-	F 65/160C	-	100.0													
-	F 65/160B	-	106.5													
-	F 65/160A	-	123.0													
-	F 65/200B	-	128.0													
-	F 65/200A	-	125.0													
-	F 65/200AR	-	153.1													
-	F 80/160D	-	111.5													
-	F 80/160C	100	80	747	405	180	225	330	250	320	60	60	18	-	126.0	
-	F 80/160B				-									143.5		
-	F 80/160A				-									153.0		
-	F 100/160C				-									139.0		
-	F 100/160B				-									153.7		
-	F 100/160A				-									165.0		

(\*weight includes counterflanges)

## ABSORPTION

MODEL	VOLTAGE (single-phase)	
	230 V	240 V
Single-phase		
Fm 32/160B	<b>15.0 A</b>	<b>13.8 A</b>
Fm 40/160C	<b>15.0 A</b>	<b>13.8 A</b>
Fm 50/125C	<b>15.0 A</b>	<b>13.8 A</b>

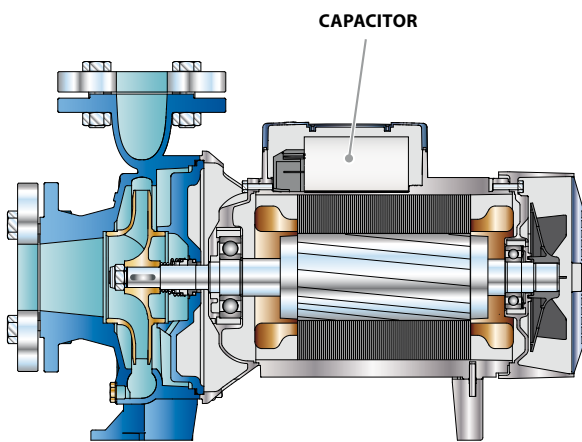

**Single-phase version**

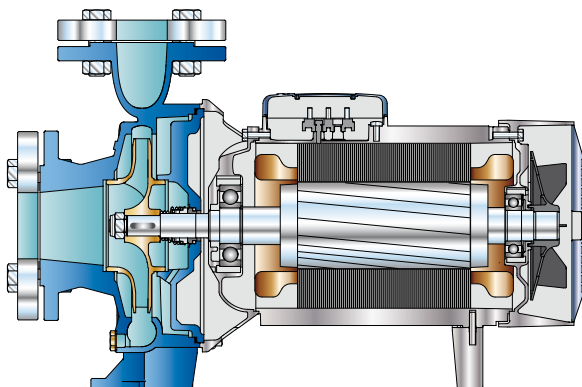

**Three-phase version**

MODEL	VOLTAGE (three-phase)		
	230÷240 V	400÷415 V	690÷720 V
Three-phase			
F 32/160C	<b>7.5 A</b>	<b>4.3 A</b>	<b>2.5 A</b>
F 32/160B	<b>10.0 A</b>	<b>5.8 A</b>	<b>3.4 A</b>
F 32/160A	<b>12.0 A</b>	<b>7.3 A</b>	<b>4.2 A</b>
F 32/200C	<b>17.9 A</b>	<b>10.3 A</b>	<b>5.9 A</b>
F 32/200B	–	<b>11.7 A</b>	<b>6.7 A</b>
F 32/200A	–	<b>14.9 A</b>	<b>8.6 A</b>
F 32/200BH	<b>12.6 A</b>	<b>7.3 A</b>	<b>4.2 A</b>
F 32/200AH	<b>15.4 A</b>	<b>8.9 A</b>	<b>5.1 A</b>
F 40/160C	<b>9.9 A</b>	<b>5.7 A</b>	<b>3.3 A</b>
F 40/160B	<b>12.0 A</b>	<b>6.9 A</b>	<b>4.0 A</b>
F 40/160A	<b>17.2 A</b>	<b>9.9 A</b>	<b>5.7 A</b>
F 40/200B	–	<b>12.6 A</b>	<b>7.3 A</b>
F 40/200A	–	<b>15.6 A</b>	<b>9.0 A</b>
F 40/250C	–	<b>21.0 A</b>	<b>12.1 A</b>
F 40/250B	–	<b>23.5 A</b>	<b>13.6 A</b>
F 40/250A	–	<b>30.5 A</b>	<b>17.6 A</b>
F 50/125C	<b>9.4 A</b>	<b>5.4 A</b>	<b>3.1 A</b>
F 50/125B	<b>12.0 A</b>	<b>6.9 A</b>	<b>4.0 A</b>
F 50/125A	<b>16.3 A</b>	<b>9.4 A</b>	<b>5.4 A</b>
F 50/160C	<b>15.8 A</b>	<b>9.1 A</b>	<b>5.3 A</b>
F 50/160B	–	<b>12.3 A</b>	<b>7.1 A</b>
F 50/160A	–	<b>15.5 A</b>	<b>8.9 A</b>
F 50/200C	–	<b>23 A</b>	<b>13.3 A</b>
F 50/200B	–	<b>29.5 A</b>	<b>17 A</b>
F 50/200A	–	<b>34.5 A</b>	<b>20 A</b>
F 50/200AR	–	<b>41.5 A</b>	<b>24 A</b>
F 50/250D	–	<b>17.2 A</b>	<b>9.9 A</b>
F 50/250C	–	<b>21.0 A</b>	<b>12.0 A</b>
F 50/250B	–	<b>27.0 A</b>	<b>15.6 A</b>
F 50/250A	–	<b>34.0 A</b>	<b>19.6 A</b>
F 50/250AR	–	<b>41.0 A</b>	<b>24.0 A</b>
F 65/125C	<b>17.5 A</b>	<b>10.0 A</b>	<b>5.8 A</b>
F 65/125B	–	<b>12.0 A</b>	<b>7.0 A</b>
F 65/125A	–	<b>16.5 A</b>	<b>9.5 A</b>
F 65/160C	–	<b>19.0 A</b>	<b>11.0 A</b>
F 65/160B	–	<b>23.0 A</b>	<b>13.5 A</b>
F 65/160A	–	<b>27.5 A</b>	<b>16.0 A</b>
F 65/200B	–	<b>30.0 A</b>	<b>17.3 A</b>
F 65/200A	–	<b>35.0 A</b>	<b>20.2 A</b>
F 65/200AR	–	<b>41.0 A</b>	<b>24.0 A</b>
F 65/250C	–	<b>53.0 A</b>	<b>31.0 A</b>
F 65/250B	–	<b>65.0 A</b>	<b>38.0 A</b>
F 65/250A	–	<b>79.0 A</b>	<b>46.0 A</b>
F 80/160D	–	<b>22.0 A</b>	<b>13.0 A</b>
F 80/160C	–	<b>29.0 A</b>	<b>17.0 A</b>
F 80/160B	–	<b>34.5 A</b>	<b>20.0 A</b>
F 80/160A	–	<b>39.0 A</b>	<b>22.5 A</b>
F 80/200B	–	<b>53.0 A</b>	<b>31.0 A</b>
F 80/200A	–	<b>65.0 A</b>	<b>38.0 A</b>
F 80/250B	–	<b>79.0 A</b>	<b>46.0 A</b>
F 80/250A	–	<b>98.0 A</b>	<b>57.0 A</b>
F 100/160C	–	<b>31.0 A</b>	<b>18.0 A</b>
F 100/160B	–	<b>36.0 A</b>	<b>21.0 A</b>
F 100/160A	–	<b>42.0 A</b>	<b>24.0 A</b>
F 100/200C	–	<b>53.0 A</b>	<b>31.0 A</b>
F 100/200B	–	<b>65.0 A</b>	<b>38.0 A</b>
F 100/200A	–	<b>79.0 A</b>	<b>46.0 A</b>
F 100/250B	–	<b>98.0 A</b>	<b>57.0 A</b>
F 100/250A	–	<b>126.0A</b>	<b>73.0 A</b>

## **REGULATION (EU) N. 547/2012**

- Minimum efficiency index  $MEI \geq 0,10$  for water pumps according to the (EU) Regulation current from the 1th of January 2013.
- The benchmark for most efficient water pumps is  $MEI \geq 0,70$ .
- The efficiency of a pump with a trimmed impeller is usually lower than that of a pump with the full impeller diameter. The trimming of the impeller will adapt the pump to a fixed duty point, leading to reduced energy consumption. The minimum efficiency index (MEI) is based on the full impeller diameter.
- The operation of this water pump with variable duty points may be more efficient and economic when controlled, for example, by the use of a variable speed drive that matches the pump duty to the system.
- Information on benchmark efficiency is available [www.europump.org/efficiencycharts](http://www.europump.org/efficiencycharts).