

TOP-GM

Submersible DRAINAGE pumps

⇒ for clear water



Version with vertical magnetic float switch



PERFORMANCE RANGE

- Flow rate up to **260 l/min** (15.6 m³/h)
- Head up to **10.5 m**

APPLICATION LIMITS

- Immersion depth:
 - **1.5 m** with 5 m long power cable
 - **3 m** with 10 m long power cable
- Maximum liquid temperature **+40 °C**
(Maximum liquid temperature +90 °C for a maximum of 3 minutes intermittent service)
- Passage of suspended solids up to **Ø 10 mm**
- Suction down to **14 mm** above ground level
- Continuous service **S1**

CONSTRUCTION AND SAFETY STANDARDS

Complete with:

- **5 m** long power cable
- vertical magnetic float switch

EN 60335-1
IEC 60335-1
CEI 61-150

EN 60034-1
IEC 60034-1
CEI 2-3



CERTIFICATIONS



INSTALLATION AND USE

The **TOP-GM** series is suitable for use with **clear water** that does not contain abrasive particles and comes complete with a vertical float switch meaning that the pumps **can be used in particularly small spaces**.

As a result of the design solutions that have been adopted, such as the complete cooling of the motor and the shaft with double seal, these pumps are easy to use and reliable.

They are suitable for use in applications such as draining small flooded areas (rooms, cellars, garages) in the event of an emergency, for the disposal of waste water in the home (from dishwashers, washing machines) and for emptying drainage traps.

PATENTS - TRADE MARKS - MODELS

- Registered Community Design n° 342159-0011

OPTIONALS AVAILABLE ON REQUEST

- Special mechanical seal
- Pumps with a **10 m** long power cable
 - ⇒ N.B. Standard EN 60335-2-41 states that the power cable must be 10 m long for outdoor applications
- Other voltages or 60 Hz frequency

GUARANTEE

2 years subject to terms and conditions

CHARACTERISTIC CURVES AND PERFORMANCE DATA

50 Hz n= 2900 1/min

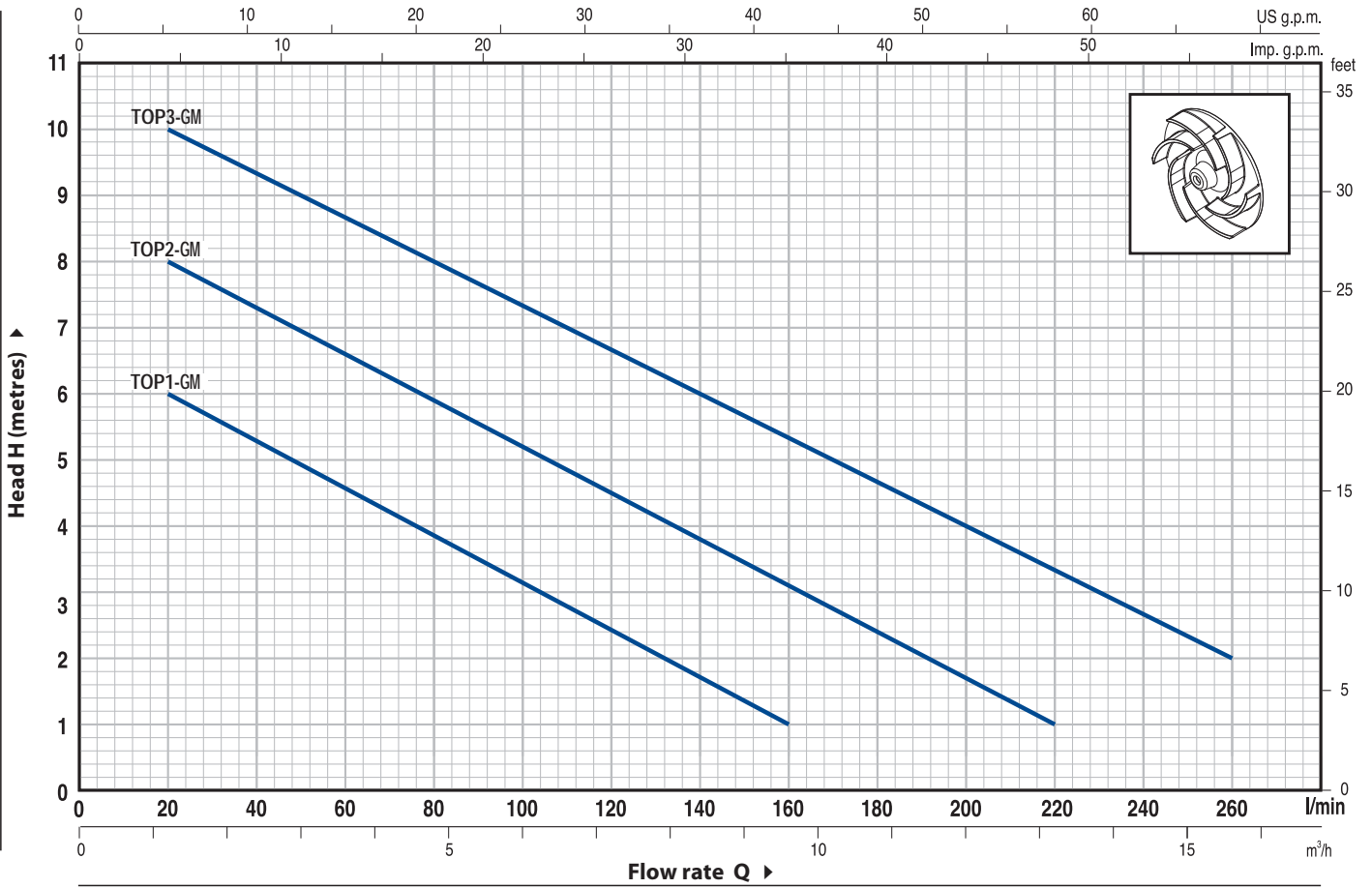

MODEL	POWER		Q	0	1.2	2.4	3.6	4.8	6.0	7.2	8.4	9.6	10.8	12	13.2	14.4	15.6
	kW	HP		0	20	40	60	80	100	120	140	160	180	200	220	240	260
Single-phase																	
TOP1-GM	0.25	0.33	H metres	7	6	5.5	4.5	4	3	2.5	1.8	1					
TOP2-GM	0.37	0.50		9	8	7.5	6.5	6	5.5	4.5	4	3	2.5	1.8	1		
TOP3-GM	0.55	0.75		10.5	10	9	8.8	8	7.5	6.5	6	5.5	4.8	4	3.5	2.5	2

Q = Flow rate H = Total manometric head

Tolerance of characteristic curves in compliance with EN ISO 9906 App. A.

POS.	COMPONENT	CONSTRUCTION CHARACTERISTICS	
1	PUMP BODY	Technopolymer	
2	SUCTION FILTER	Technopolymer	
3	SUCTION PLATE	Stainless steel AISI 304	
4	DIFFUSER	Technopolymer	
5	IMPELLER	Noryl GFN2V	
6	MOTOR CASING	Stainless steel AISI 304	
7	MOTOR CASING PLATE	Stainless steel AISI 304	
8	MOTOR SHAFT	Stainless steel EN 10088-3 - 1.4104	
9	SHAFT WITH DOUBLE SEAL AND OIL CHAMBER		
	<i>Seal</i>	<i>Shaft</i>	<i>Materials</i>
	<i>Model</i>	<i>Diameter</i>	<i>Stationary ring</i> <i>Rotational ring</i> <i>Elastomer</i>
	AR-12R	Ø 12 mm	Ceramic Graphite NBR
10	LIP SEAL	Ø 12 x Ø 19 x H 5 mm	
11	BEARINGS	6201 ZZ / 6201 ZZ	
12	CAPACITOR		
	<i>Pump</i>	<i>Capacitance</i>	
	<i>Single-phase</i>	<i>(230 V or 240 V)</i>	<i>(110 V)</i>
	TOP 1-GM	6.3 µF 450 VL	16 µF 250 VL
	TOP 2-GM	10 µF 450 VL	16 µF 250 VL
	TOP 3-GM	14 µF 450 VL	16 µF 250 VL
13	ELECTRIC MOTOR		
	<ul style="list-style-type: none"> - Single-phase 230 V - 50 Hz with thermal overload protector built-in to the winding - Insulation: F class - Protection: IP 68 		
14	HANDLE ASSEMBLY (resin sealed)		
	Complete with: <ul style="list-style-type: none"> - 5 metre long "H07 RN-F" power cable with Schuko plug - Float switch. 		
15	HOSE CONNECTOR WITH UNION		
	Ø 25 mm hose connection for TOP 1 Ø 35 mm for TOP 2-3		

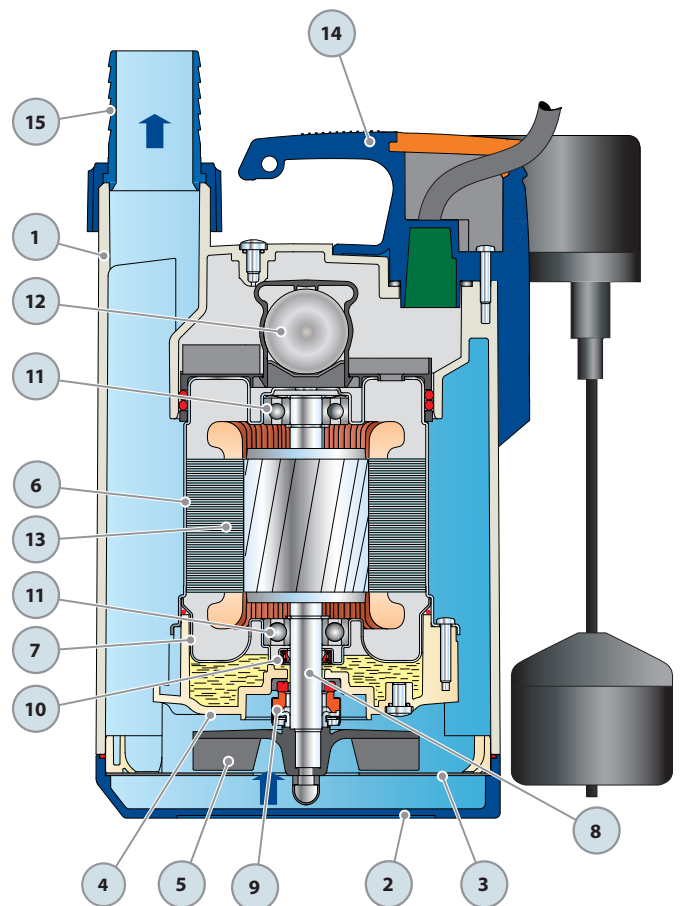

DIMENSIONS AND WEIGHT

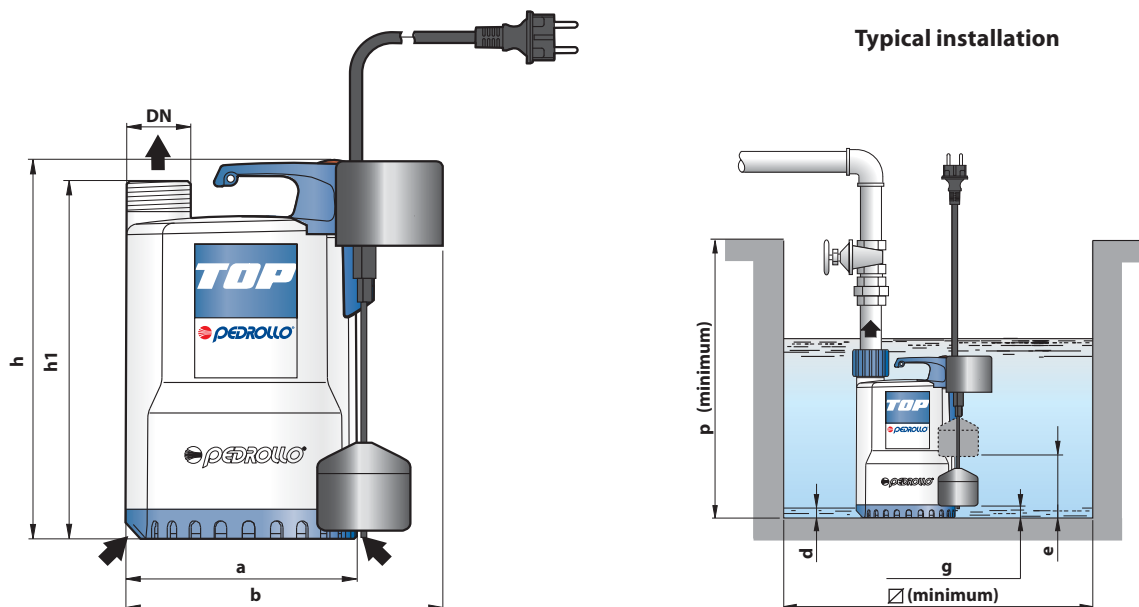

MODEL	PORT DN	DIMENSIONS mm									kg
		a	b	h	h1	d	e	g	p	Ø	
Single-phase											
TOP 1-GM	1¼"	152	200	257	237	14	140	35	350	220	4.6
TOP 2-GM				287	267		170	40			
TOP 3-GM											

ABSORPTION

MODEL	VOLTAGE (single-phase)		
	230 V	240 V	110 V
Single-phase			
TOP 1-GM	1.3 A	1.3 A	3.0 A
TOP 2-GM	2.0 A	2.0 A	5.3 A
TOP 3-GM	3.2 A	3.2 A	7.9 A

PALLETIZATION

MODEL	GROUPAGE			CONTAINER		
	n° pumps	H (mm)	kg	n° pumps	H (mm)	kg
Single-phase						
TOP 1-GM	96	1260	459	168	2100	790
TOP 2-GM	96	1260	526	168	2100	910
TOP 3-GM	96	1500	660	144	2180	982

